

7. TROUBLE SHOOTING AND MAINTENANCE

INSTALLATION

No Operation.	Power is not supplied. Incorrect wiring. Low power supply.	Supply power Correct wiring Supply power between 9 to 18VDC
Unit is constantly in warm-up mode.	Low power supply.	Supply power between 9 to 18VDC

TROUBLE SHOOTING

Yellow LED does not light. (MW does not operate.)	Check LED On/Off	Check if it detects near from.	Increase Sensitivity (section 6-B).
Green LED does not light. (PIR does not operate.)	Switch and turn.	Check if it detects near from.	Remove blocking materials and conduct walk test again.
Yellow LED lights even if no person in detection area (MW detects)	Strong RFI nearby. Moving fan or motor of air-conditioning vents etc.	Detection outside through wall. (Persons in the next room, Water pipe in the wall etc.)	Switch electrical equipment off.
	Movements of animals, curtains etc.		Adjust the detection range (section 6-B) and reduce sensitivity.
			Remove them from the detection area.
Green LED lights even if no person in detection area (PIR detects)	Wind direct hits detector. Strong light hits detector. (sunlight, car head light etc.)	Rapid temperature changes in detection area (heating, air conditioning, incandescent lamp etc.) moving animals, or curtains etc.	Avoid them from hitting detectors directly. Possibly, better to avoid it from the detection area.
			Remove such objects from detection area.
Red & Yellow LED flicker.	Failure of microwave unit		Replace with new unit
Green & Yellow LED flicker.	Blocking materials in front of detector.		Remove blocking materials.
No output although Green & Yellow (or Red & Yellow) LED flicker.	Trouble Output Switch is OFF.		Turn it ON.
	Incorrect wiring		Correct wiring
	Relay is broken.		Replace with new unit
No output although Red LED lights.	Incorrect wiring		Correct wiring
	Relay is broken.		Replace with new unit
Red LED continues to light	Incorrect wiring of Alarm Memory		Correct wiring
	Improper Control Voltage from control panel.		Check control voltage.

CONDUCT WALK TEST AT LEAST ONCE A YEAR.

8. SPECIFICATIONS

DX-40,DX-60

Detection method	Passive Infrared and Micro Wave	
Model	DX-40	DX-60
Coverage	40ft x 40ft (12m x 12m)85°wide	60ft x 60ft (18m x 18m)85°wide
Detection zones	82 zones(PIR)	
Mounting Height	5 ~ 8ft(1.5 ~ 2.4m)	6 ~ 8ft(1.8 ~ 2.4m)
Sensitivity	3°F (1.6°C) at 2ft / sec (0.6m / sec)40ft (12m)	3°F (1.6°C) at 2ft / sec (0.6m / sec)60ft (18m)
Detectable speed	1 ~ 5ft / sec (0.3 ~ 1.5m / sec)	
Alarm period	Approx. 2 sec	
Alarm output	N.C., 28VDC 0.2A max.	
Tamper switch	N.C., Open when cover is removed.	
Warm up period	Approx. 30 sec	
LED indicator	Flicker during warm-up. RED : ALARM , ALARM MEMORY and TROUBLE indicator YELLOW : MW and TROUBLE indicator GREEN : P.I.R. and TROUBLE indicator	
Power input	9 ~ 18VDC	
Current draw	12mA (normal) , 35mA (max.) at 12VDC	
RF interference	NO Alarm 30V / m	
Operating temperature	14°F ~ 122°F (-10°C ~ +50°C)	
Environmental humidity	95% max.	
Microwave Frequency	9.900GHz	
	10.525GHz	
Weight	5.3oz (150g) : PLASTIC ANTENNA Version	
	8.1oz (230g) : METAL ANTENNA Version	

DX-40 PLUS,DX-60 PLUS

Current draw	17mA (normal) , 40mA (max.) at 12VDC
D.L. terminal	See Section 6-A
Alarm Memory	See Section 6-F
Trouble Output	N.C., 28VDC 0.2A max.
Microwave Frequency	9.900GHz
	10.525GHz
	10.687GHz (U.K.Version)

Dimensions

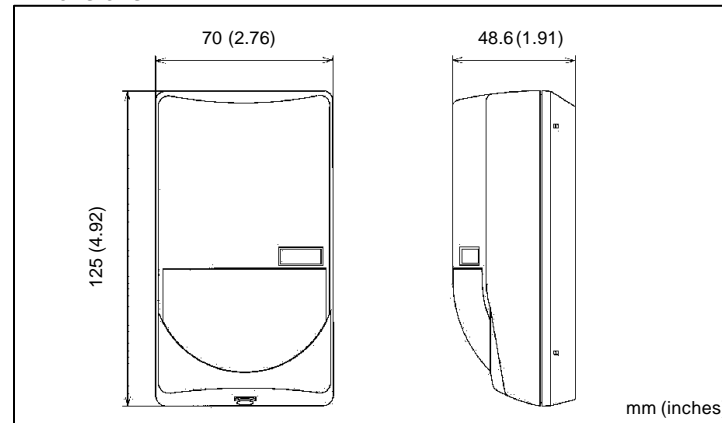

* Specifications and design are subject to change without prior notice.

NOTE

This unit is designed to detect movement of an intruder and activate an alarm control panel. Being only a part of a complete system, we cannot accept responsibility for any damages or other consequences resulting from an intrusion. This Product conforms to category of EC Directives. 89/336 EEC. 1999/5/EC.



PASSIVE INFRARED and MICROWAVE COMBINATION DETECTOR

DX-40 , DX-60 , DX-40 PLUS , DX-60 PLUS



FEATURES

DX-40,DX-60,DX-40PLUS and DX-60PLUS

- Microwave Area Shaping Technology (Patent Pending)
- Multifocus Optics Design (Patented)
- Automatic TROUBLE Monitoring (Patent Pending)
- Microwave "Watchdog" Circuit
- QUAD Zone Logic
- Temperature Compensation Logic
- Hassle-free Microwave Adjustment
- Sealed Optics
- 3 LED Walk Test Indication

-LED On/Off Switch

DX-40,DX-40PLUS Only

- Pet Immunity

DX-40PLUS,DX-60PLUS Only

- Separate Relay Output for Automatic Trouble Monitoring
- Alarm Memory
- LED Remote Control Terminal

OPTIONAL BRACKET

FA-1W : Wall Mount Bracket : adjustable ±45° (Horizontally), 0-20° (Vertically downwards)

FA-3 : Compact Wall & Ceiling Bracket : adjustable ±45° (Horizontally), 0-10° (Vertically downwards)

1. INSTALLATION HINTS

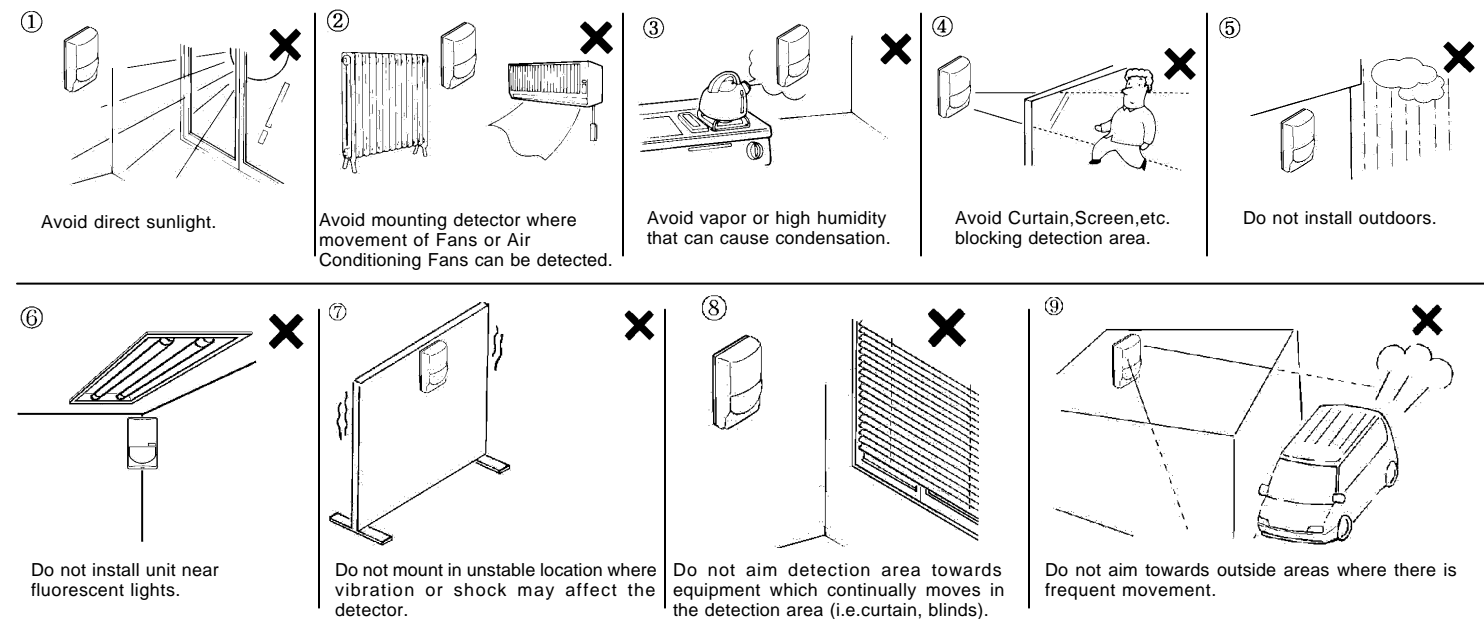

2. DESCRIPTION AND OPERATION

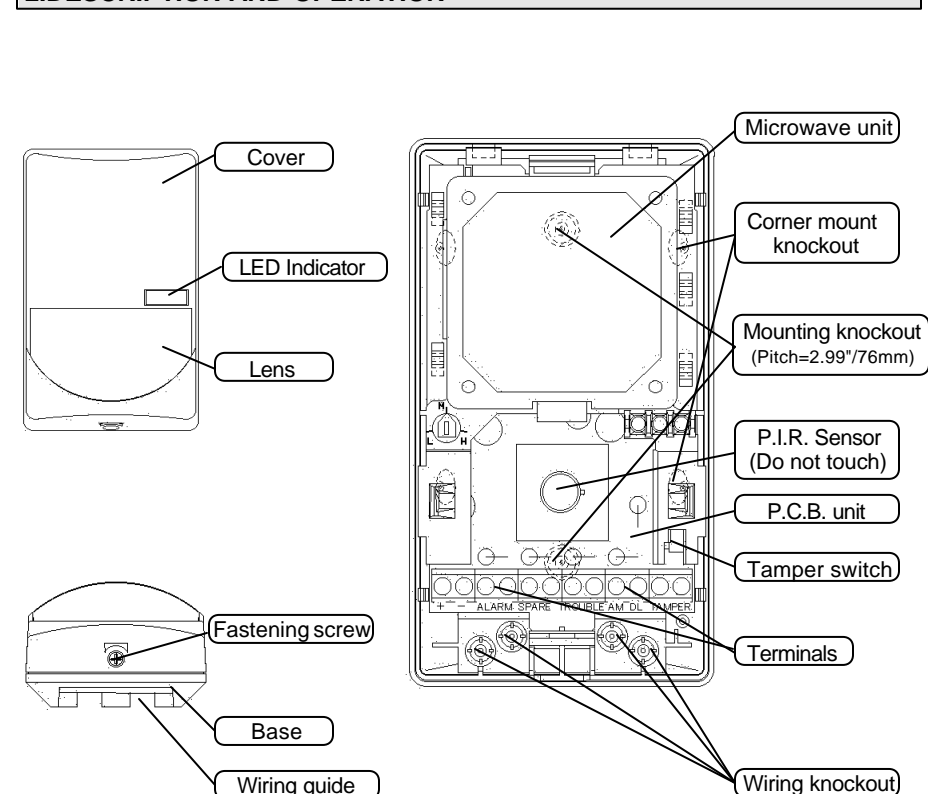

3. DETECTION AREA

TOP VIEW

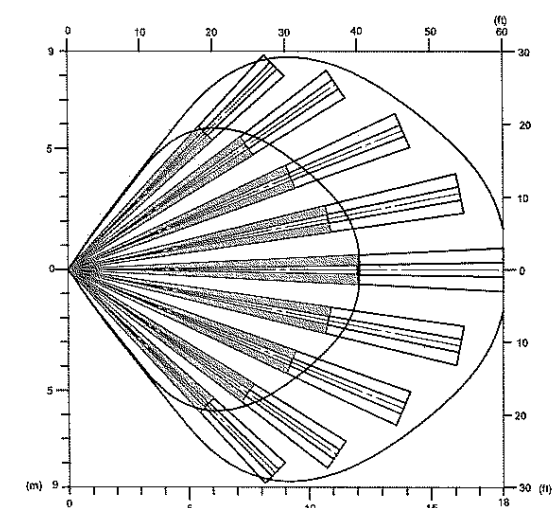

SIDE VIEW

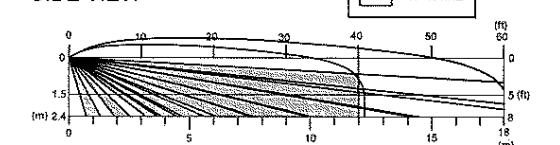

OPTEX CO., LTD. (ISO 9001 Certified by LRQA)
2-7-5 Minamigano Cho, Saitama-shi, Japan
TEL: (077)524-6647 FAX: (077)522-9522

OPTEX INCORPORATED
10450 206th Street Torrance, CA 90501-1010 U.S.A.
TEL: (310)633-1600 FAX: (310)633-5912

OPTEX (EUROPE) LTD. (ISO 9002 Certified by NQA)
Chesham Road, Chesham Park, Maidenhead, Berkshire, SL6 7BU U.K.
TEL: (0760)931160 FAX: (0760)936311

4. INSTALLATION

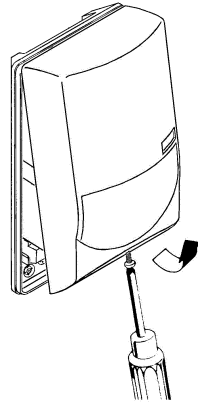

Loosen fastening screw and remove cover.

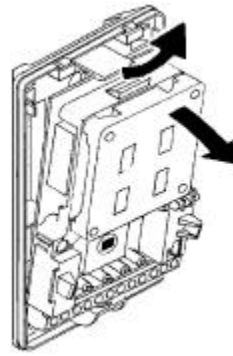

Release hook at top of unit. Remove P.C.B. unit from base.

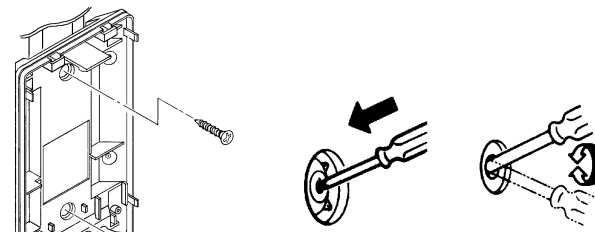

Lead in wires through knockouts along the wiring guide on the rear side of base. Mount base with supplied screws. When pet immunity is required, refer to Section 6-E. When using a bracket, check matching knockout position before opening mounting hole.

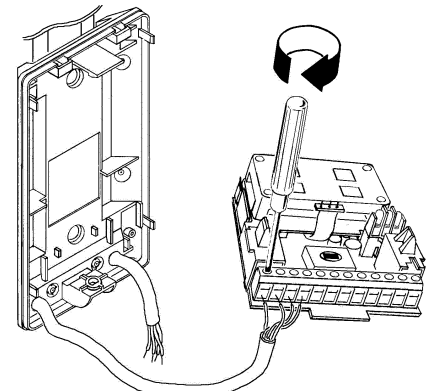

Wire according to Section 5.

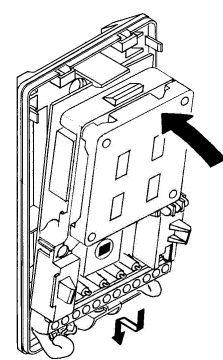

Fix P.C.B. unit into base. Supply power. Allow 30 sec to warm up.

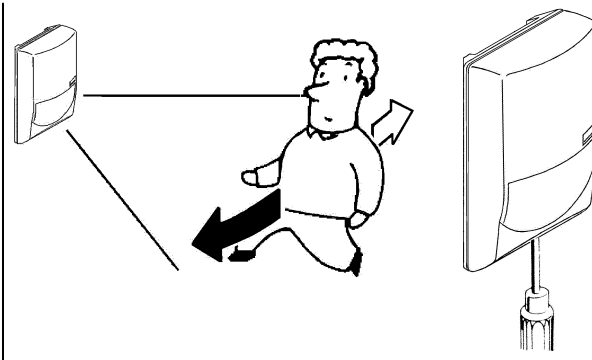

Conduct walktest and make adjustments. (Section 6) Fit cover using fastening screw.

5. WIRING

DX-40, DX-60

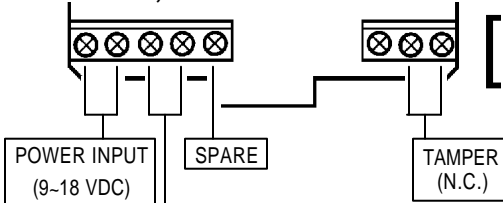

TAMPER terminals to be connected to a 24 hour supervisory loop.

ALARM OUTPUT and TROUBLE OUTPUT (N.C.)
*See Section 6-C

Power wires should not exceed the following lengths.

WIRE SIZE	DX-40,DX-60		DX-40 PLUS,DX-60 PLUS	
	12V	14V	12V	14V
AWG 22(0.33mm ²)	160m (530ft)	320m(1060ft)	140m(460ft)	280m(930ft)
AWG 20(0.52mm ²)	250m (830ft)	500m(1660ft)	220m(730ft)	440m(1460ft)
AWG 18(0.83mm ²)	400m (1330ft)	800m(2660ft)	350m(1160ft)	700m(2330ft)

When using two or more units on one wire, the maximum length is obtained by dividing the maximum wire length listed above by the number of units used.

DX-40 PLUS,DX-60 PLUS

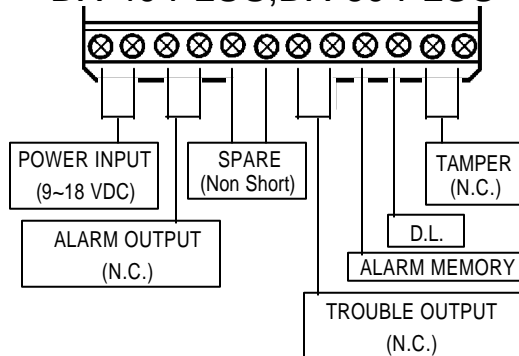

6. FUNCTIONS

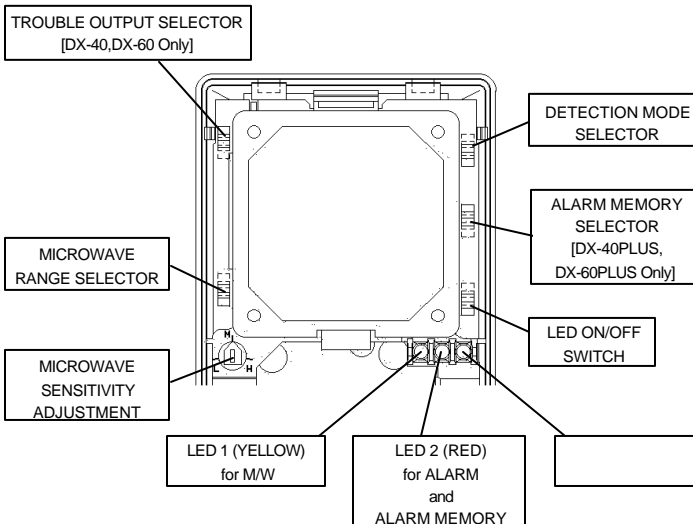

6 - A. LED ON/OFF

Switch On or Off by adjusting the pin switch. LED will turn on under following status even if the pin switch is positioned to Off.

- 1) During warm-up period (approx. 30 seconds)
- 2) Alarm Memory indication
- 3) To indicate TROUBLE status (refer Section 6-C)

* D.L. terminal / LED remote control terminal (DX-40 PLUS,DX-60 PLUS Only)
LED can be enabled or disabled remotely from control panel by D.L. terminal. Place jumper pin switch in OFF position.

LED Enabled	Connect D.L. terminal to common ground (with detector).
LED Disabled	No ground to D.L. terminal (open circuit).

6 - B. MICRO WAVE ADJUSTMENT

Adjust microwave detection area by RANGE SELECTOR & SENSITIVITY ADJUSTMENT.

- 1) Select RANGE SELECTOR according to the room size

DX-40,DX-40PLUS LONG :10 - 12m (33ft-40ft) DX-60,DX-60PLUS LONG :12 - 18m (40ft-60ft)
SHORT : 5 - 9m (17ft-30ft) SHORT : 6 - 12m (20ft-40ft)

- 2) Position SENSITIVITY ADJUSTMENT to L firstly, then, along with walk testing, turn to H gradually until you get detection at the longest distance for the required detection range.

Guidance of SELECTOR and ADJUSTMENT position

RANGE SELECTOR	Short	Short	Short	Long	Long	Long	
SENS. ADJUSTMENT	L	M	H	L	M	H	
Detection	DX-40,DX-40PLUS	5m(17ft)	7m(23ft)	9m(30ft)	10m(33ft)	11m(37ft)	12m(40ft)
Range	DX-60,DX-60PLUS	6m(20ft)	9m(30ft)	12m(40ft)	12m(40ft)	15m(50ft)	18m(60ft)

The chart shows any example of adjustments which may differ depending upon the size and shape of the installation site. For good adjustment, conduct walk test according to above 2).

IMPORTANT

If Microwave detection range is set too wide, it may detect movements outside of the detection area, resulting in false alarms. **Do not adjust sensitivity too high.**

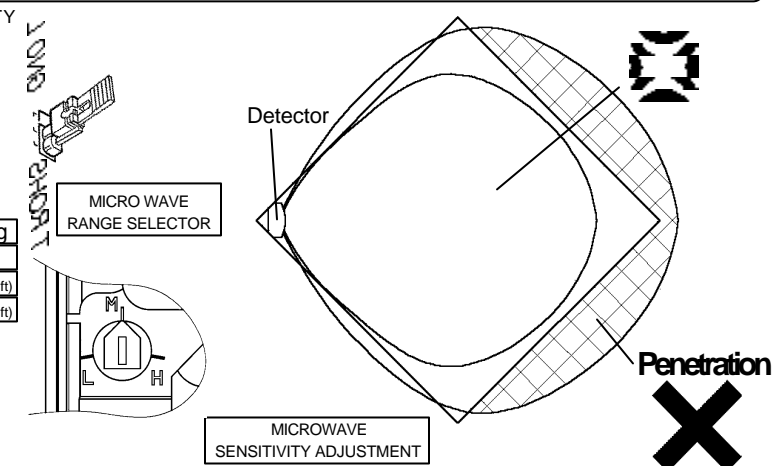

6 - C. AUTOMATIC TROUBLE MONITORING

DX-40,DX-60 series features automatic trouble monitoring which generate trouble signal when detection ability of PIR or Microwave is compromised.

1) PIR detection failure

- Function

When something is blocking the PIR detection ability very near the detector (up to approx. 20 cm), i.e. by paper, this function will generate a TROUBLE signal. It requires the area to be blocked for approx. 30 seconds or less.

- Reset of TROUBLE Output

Remove blocking material and conduct a walk test. If PIR detects properly, TROUBLE output will reset.

- Caution

- Do not switch power down the detector during a TROUBLE status. (It will reset TROUBLE output even if blocking material remains.)
- Cannot detect blocking away from the detector (up to approx. 20 cm)
- In order for this feature to activate, an object must be placed within 20cm of the detector which will reflect microwave. After this occurs, the detector counts any PIR detection's for or up to 30 seconds, and if there are no PIR detection's, the unit will generate a trouble signal. If there is nothing to reflect microwave within 20cm of the detector, the trouble signal will not be sent, even if the PIR is blocked (i.e. Spray).

2) Microwave detection failure (Self-Check)

- Function

This function monitors signal wave shape of PIR and microwave's human detection, and inspect microwave's failure. Analysis requires an average of 10 to 20 minutes.

Microwave "Watchdog" Circuit
When microwave operation fails, the detector automatically switches to back-up mode. In this mode, the PIR operates independently in order to avoid missing alarms during microwave failure. Detection mode (refer to section 6-D) turns into SP (Special) mode for enhanced reliability.

3) TROUBLE Output Indication

When TROUBLE status occurs, the following output will operate continually until the trouble is restored, i.e. blocking material of PIR is removed.

- LED Operation

PIR Detection Failure : Yellow and Green LED's flicker.
Microwave Detection Failure : Red and Yellow LED's flicker.

- Relay Output Terminals

DX-40,DX-60
TROUBLE signals will output through the ALARM output terminals.

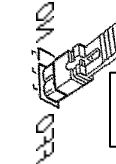

SELECTOR POSITION	ALARM OUTPUT TERMINAL
ON	Output ON
OFF	No Output (LED Indication only)

NOTE: When Alarm Output (ON) is selected and the detector goes into a trouble condition, the Alarm Output will open and remain in the open position. When the relay output is latched because of this type of trouble condition, the PIR only mode will not work. If PIR only mode is required, select Alarm Output (OFF) and trouble will be indicated by LED only.

DX-40PLUS,DX-60PLUS

TROUBLE signals will output through TROUBLE output terminals. Yellow and Green LED's flickers in turn.

6 - D. DETECTION MODE

Select STD(Standard) or SP(Special) position according to environment conditions.

STD : Select this position usually. Signals are analyzed twice. High reliability and sharp detection are available in this mode.

SP : For bad environments with moving objects in the detection area (i.e. pets or animals).

Signals are analyzed 4 times for enhanced reliability. When walk testing, detection can be a little slower than STD mode.

6 - E. SPECIAL INSTRUCTIONS FOR PET IMMUNITY

[DX-40,DX-40 PLUS Only]

When there are animals or pets in the eured area, these directions must be followed properly.

- 1) Installation height must be between 7.0 ft and 8.0 ft (2.1 m and 2.4m).
- 2) DETECTION MODE must be positioned to SP (Special).
- 3) Pet Immunity reduces for animals of 1.5 ft. (50cm) or taller.
- 4) When animals or pets jump up on desks or shelves, the detector may detect them. Aim detection area to avoid such places.
- 5) Installation should be made flat on wall or corner mounted. Do not use optional bracket if pet immunity is required.

6 - F. ALARM MEMORY

[DX-40 PLUS,DX-60 PLUS Only]

Compatible Control Panel is required for Alarm Memory.

Select "POSITIVE" or "NEGATIVE" control.

Connect A.M. terminal to Control Panel's Control Voltage Signal terminal (System Arming Status Voltage Output).

Position	Negative	Positive
System armed	0-1VDC (grounded)	OPEN or +5-18VDC
System disarmed	OPEN or +5-18VDC	0-1VDC (grounded)

"grounded" = A.M. terminal is electrically connected with power supply terminal (ground).

OPERATION OF ALARM MEMORY

When the unit triggered during armed period, then the system is disarmed, Red LED will remain lit to confirm that it reported an alarm.

- Alarm Memory will operate even when LED is switched OFF.
- Alarm Memory will not operate while system is disarmed.
- After Alarm Memory latches, Alarm Output and Red LED operate normally during armed period.

RESET

Alarm Memory resets automatically when system is re-armed.